



RUTLAND COUNTY
GARDEN FURNITURE

Hand-Crafted

ASSEMBLY INSTRUCTIONS

BARLEYTHORPE BENCH

Before you commence the assembly process, we recommend that you read these instructions thoroughly beforehand to familiarise yourself with the assembly process and to also check that you have the correct components. If for any reason you need assistance, you can find our contact details on the final page of these instructions.

We highly recommend that any assembly is carried out on a flat, level surface if possible and that you use another person to assist you if necessary.

PACKAGE CONTENTS

- 1 x Seat panel
- 1 x Seat backrest
- 2 x A-frame
- 2 x Backrest support
- 2 x Brace
- 20 x M8 Coach screws - 60mm
- 20 x Cover caps

* 8ft version additionally includes - 1 x centre support and braces, 6 x 60mm Coach screws and 6 x cover caps. The 4ft version only has 1 x straight brace.

TOOLS REQUIRED

- 10mm socket or spanner



THE BARLEYTHORPE BENCH

BARLEYTHORPE BENCH

Step 1

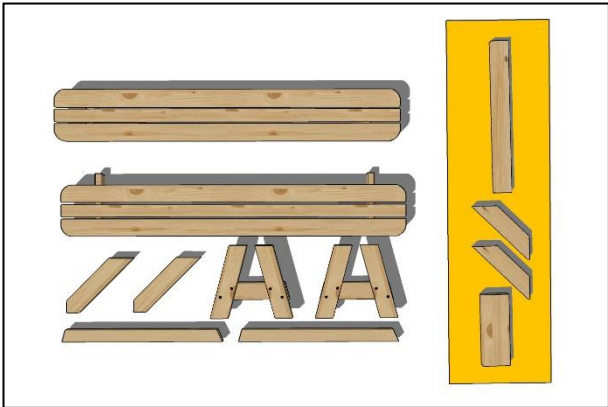

Ensure that you have all of the correct parts as listed on the front page of these instructions, including any fixings. (The parts highlighted in orange are the centre support parts for an 8ft and the brace for a 4ft)

Step 2

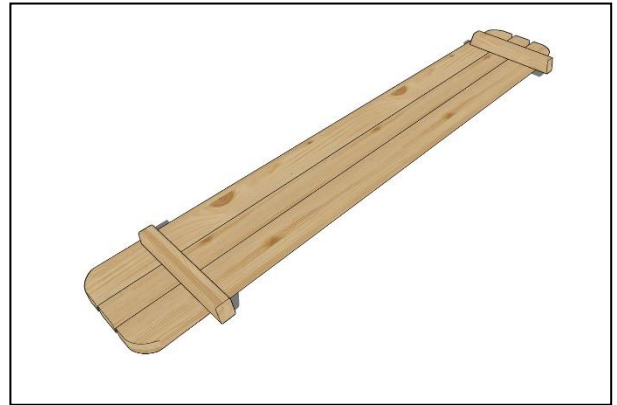

Lay the Seat panel upside down on a clean, flat surface taking care not to damage it.

Step 3



Place one of the A-frames centrally against the fixing batten ensuring that the gap at the bench edge is the same on both sides.

Step 4



Now, using 4 of the supplied 60mm coach screws and the pre-drilled holes, secure the A-frame to the fixing batten on the Seat panel and then repeat for the remaining A- frame.

BARLEYTHORPE BENCH

Step 5

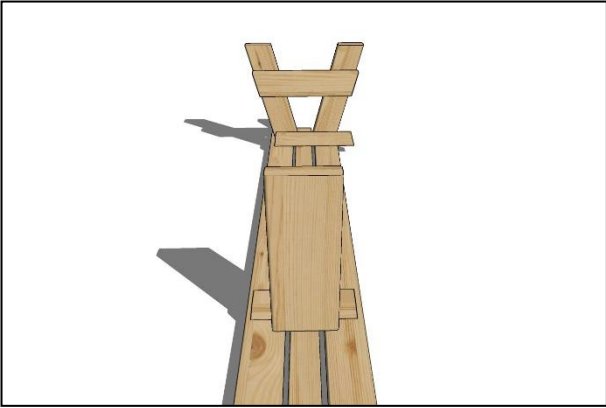

For an 8ft model, please now follow Steps 5 to 9. For other models proceed to Step 10.

Position the Centre support adjacent to the centre batten, aligned centrally on the seat panel.

Step 6

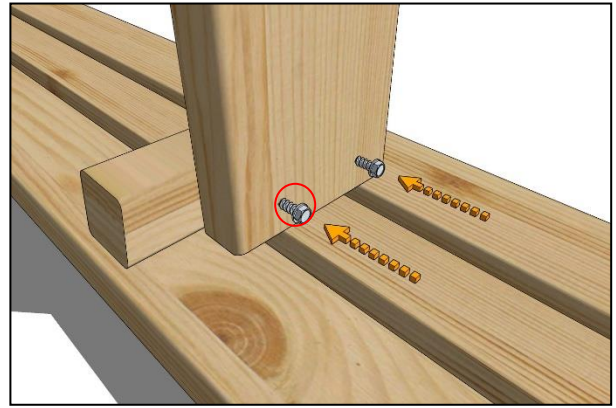

Fix into place with 2 x 60mm coach screws as shown.

Step 7

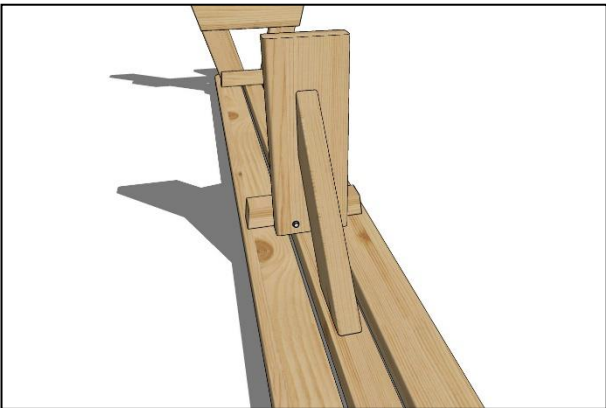

Align one of the Centre braces so that it central across the Seat panel and the ends are flat against the Seat panel and the Centre support.

Step 8

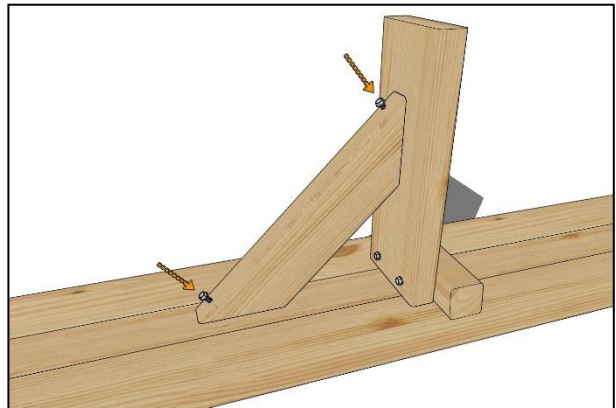

Fix into place with 2 x 60mm coach screws as shown.

BARLEYTHORPE BENCH

Step 9

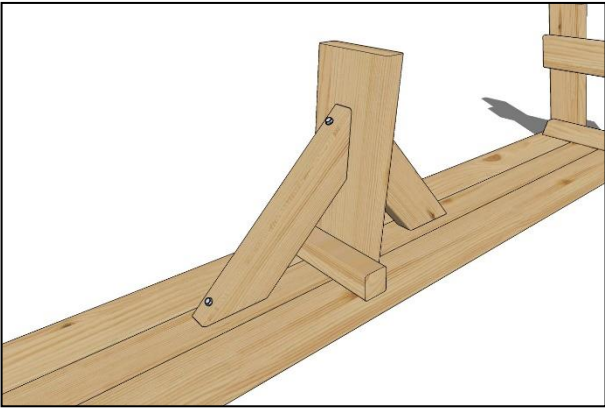

Attach the second Centre brace in the same fashion.

Step 10

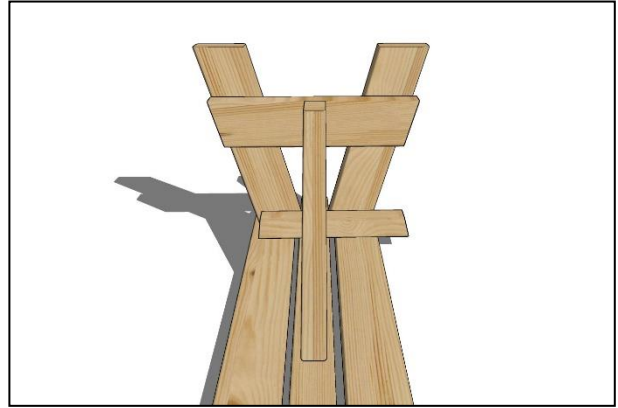

For a 4ft model now proceed to Step 13.
Place a brace, aligned centrally on the seat as shown.

Step 11

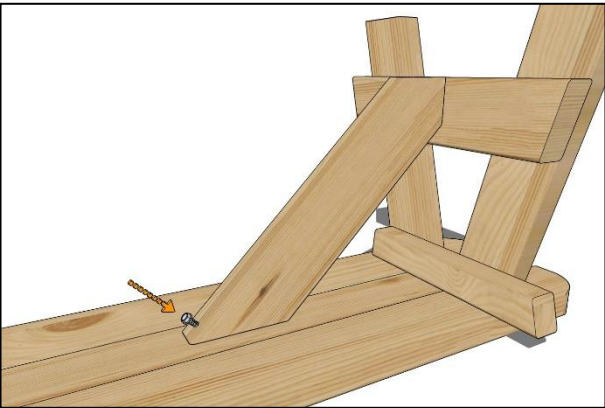

Fix to the bench with a 60mm coach screw into the Seat panel...

Step 12

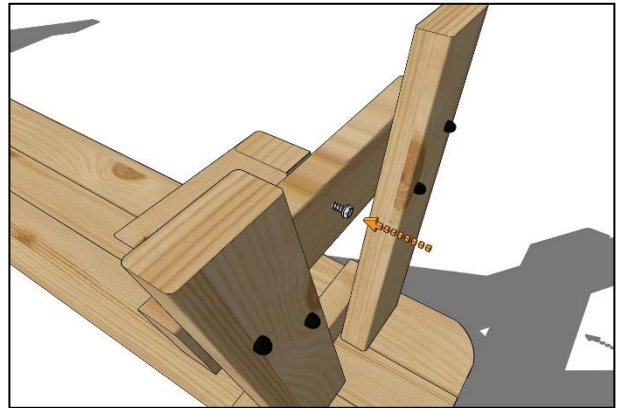

...and another 60mm coach screw through the A-frame into the brace.

BARLEYTHORPE BENCH

Step 13

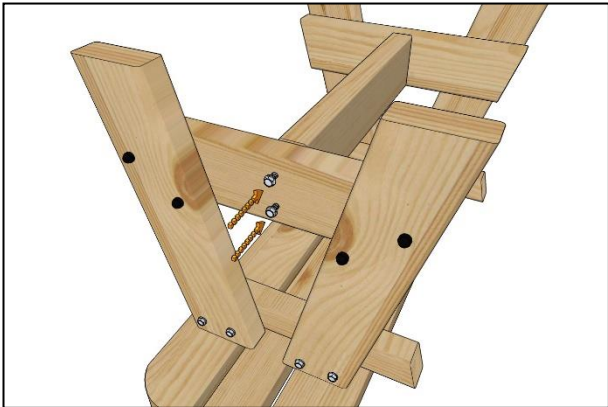

For a 4ft set, take one of the bench braces and align it between the two A-frames before securing into place using 2 x 60mm coach screws at either end as shown.

Step 14

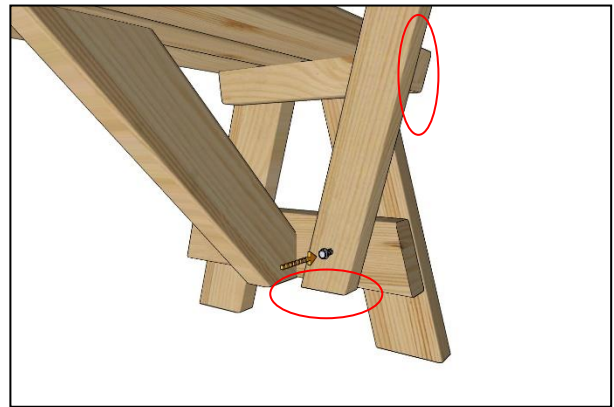

Turn the bench right way up and line up one of the pre-drilled Backrest supports so that the bottom is flush with the bottom brace and the back edge is flush with the under-seat batten as shown. Fix in place with a 60mm coachscrew at the bottom of the Backrest support...

Step 15



...and another 60mm coach screw through the under-seat batten. Repeat for the remaining Backrest support.

Step 16

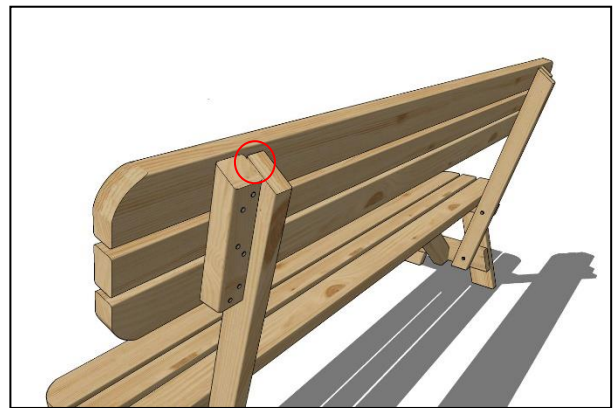

Line up a Backrest so that the tops of the Backrest supports are flush with the battens as shown, before securing into place at each end with 2 x 60mm coachscrews...

BARLEYTHORPE BENCH

Step 17



...at each end of the Backrest.

Step 18



Finally, cover any exposed coach screw heads with the cover caps provided. Your Barleythorpe bench is now complete.

WE HOPE THAT YOU FOUND YOUR PRODUCT QUICK AND EASY TO ASSEMBLE BUT IF NOT AND YOU REQUIRE ANY FURTHER ASSISTANCE OR HAVE ANY QUESTIONS YOU CAN CONTACT US BY TELEPHONE ON: 01778 440803

EMAIL: INFO@RUTLANDCOUNTYGARDENFURNITURE.CO.UK

WWW.RUTLANDCOUNTYGARDENFURNITURE.CO.UK

Rutland County Garden Furniture Ltd, Ashbourne House, 2 Dovecote Meadows,
Aslackby, Sleaford, Lincs, NG34 0HZ.
Company No: 11025348 VAT No: 282569762