



RUTLAND COUNTY  
GARDEN FURNITURE

*Hand-Crafted*

# ASSEMBLY INSTRUCTIONS

## THE BARROWDEN SET





Before you commence the assembly process we recommend that you read these instructions thoroughly beforehand to familiarise yourself with the assembly process and to also check that you have the correct components. If for any reason you need assistance, you can find our contact details on the final page of these instructions.

We highly recommend that any assembly is carried out on a flat, level surface if possible and that you use another person to assist you if necessary.

**Please note:** Whilst a single width seat is shown here, the assembly process is identical for all Barrowden seat models. When checking your components, only the companion and combo seats will contain the table section element. Also, the components listed are per seat so these will be doubled or tripled in quantity depending on the model you have purchased. The assembly process shown here is for our Barrowden dining table. However, the same process applies to *all* of our Barrowden table models.

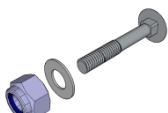
**Tools required:** 13mm and 10mm socket or spanner, Hammer

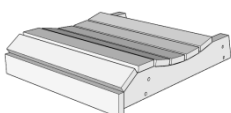
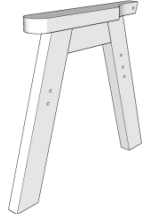
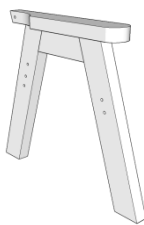
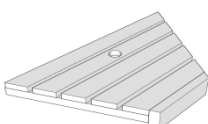
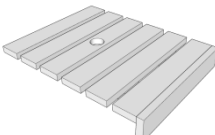
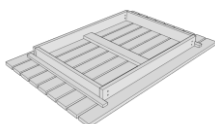
### Components

M8 Nut, bolt and washers	1 x M8 120mm coachscrew	1 x Seat back panel	1 x Seat panel	1 x Right arm frame
				
1 x Left arm frame	(Optional) Angled table section(s)	(Optional) Straight table section(s)	1 x Table top	4 x Table leg
				

# THE BARROWDEN SET

## Step 1

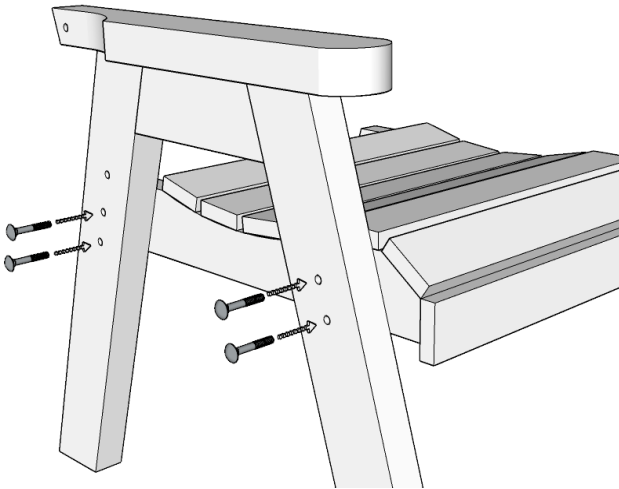

Attach the Left arm frame to the Seat panel as shown using 4 of the M8 bolts. If required, use a hammer to drive the bolts fully home...

## Step 2

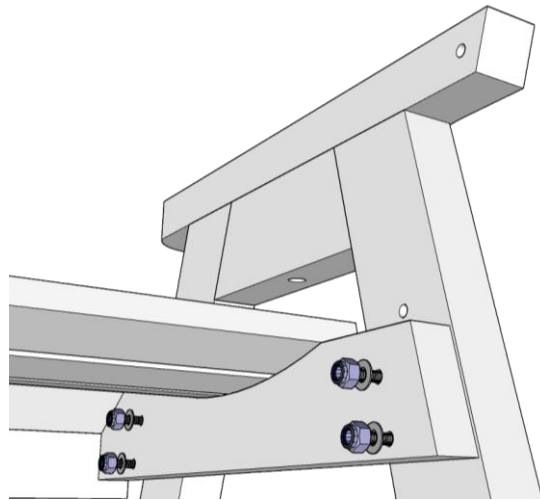

...and secure in place with 4 of the washers and nuts as shown. Do not fully tighten the nuts at this stage.

## Step 3

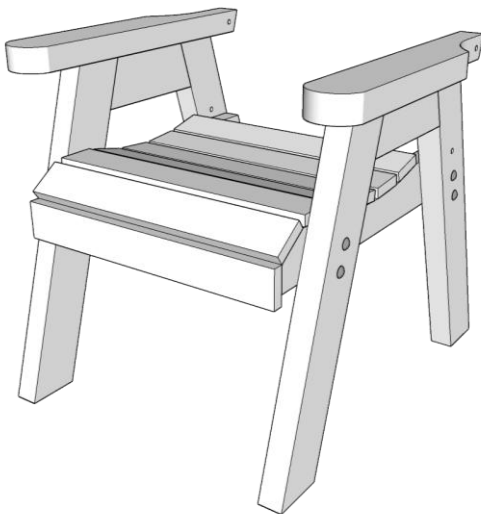

Affix the Right arm frame to the other side of the Seat panel in the same way.

## Step 4



Position the Seat back panel as shown and fix into place using the remaining fixings, again using a hammer if necessary. Now fully tighten *all* of the nuts and bolts. The Barrowden seat is now complete. For companion seats, please consult step 5 onwards.

# THE BARROWDEN SET

## Step 5

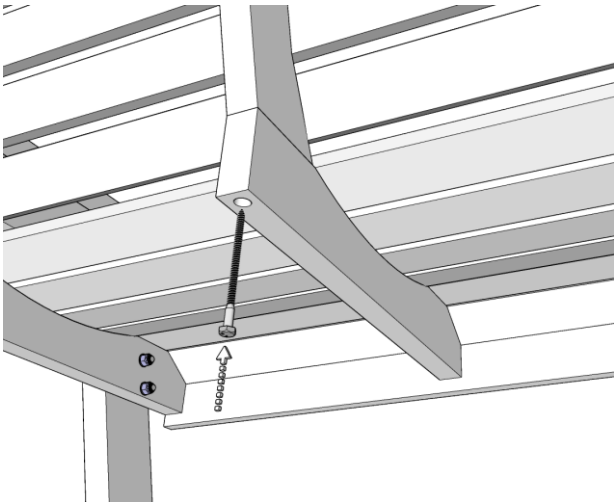

For a double or triple seat attach the centre strut of the Seat panel to the Seat back panel using the M8 120mm coachscrew .

## Step 6

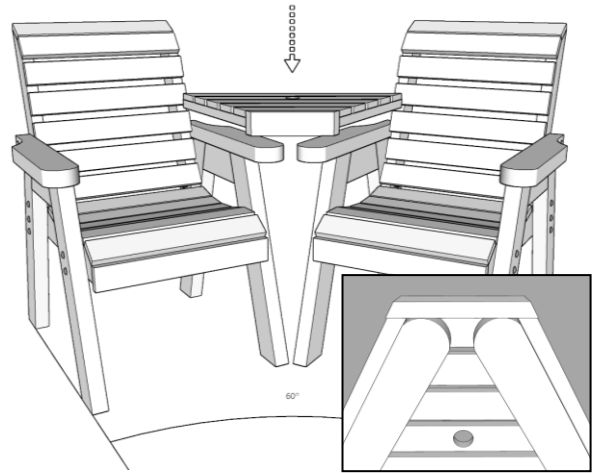

For an angled companion seat place 2 Barrowden seats as shown - at an angle of around 60° to each other. Now lower the table section into place. Adjust the position of the seats so that the seat edges are aligned with the table section outer frame.

## Step 7

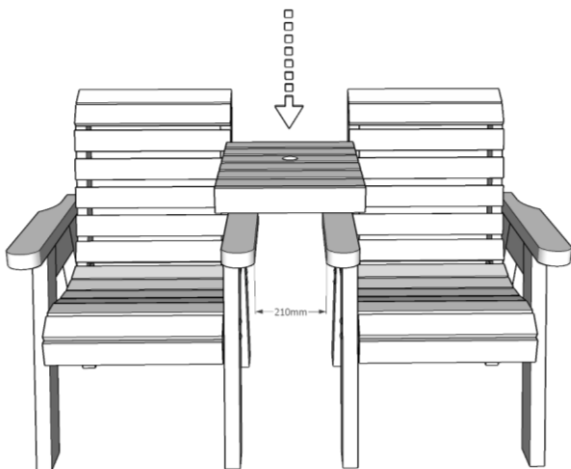

For a straight companion seat place 2 seats parallel to each other and 21cm apart. Now lower the table section into place.

## Step 8

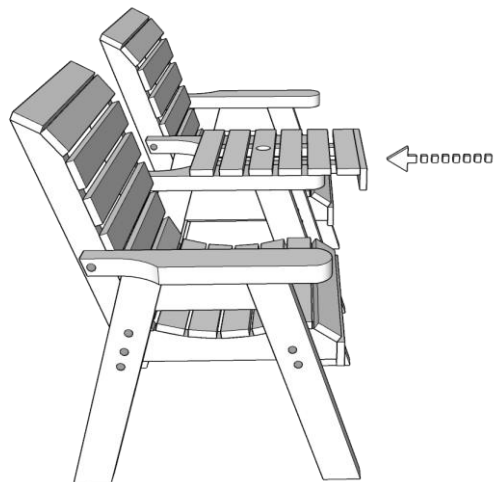

If necessary slide the table section backwards until it stops.

# THE BARROWDEN SET

## Step 9

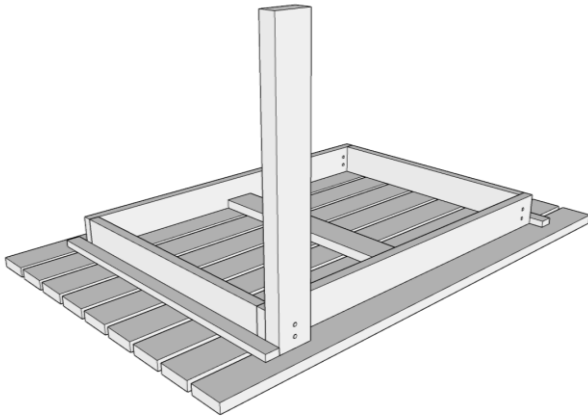

Place the table top upside down as shown and take one leg so that the holes in the leg are aligned with those in the table top.

## Step 10

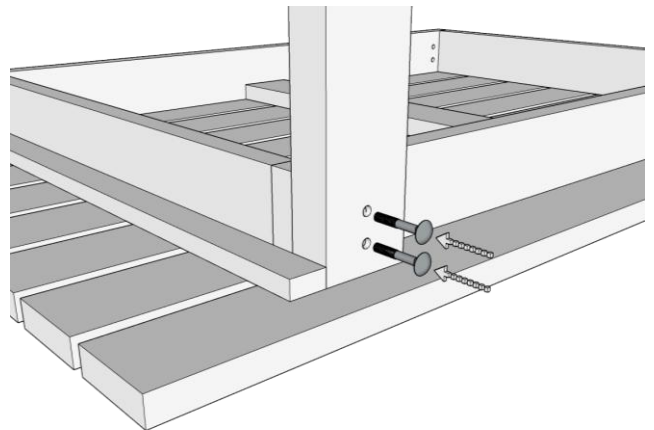

Now push 2 of the M8 bolts into the holes, using the hammer if necessary to drive the bolts fully into place.

## Step 11

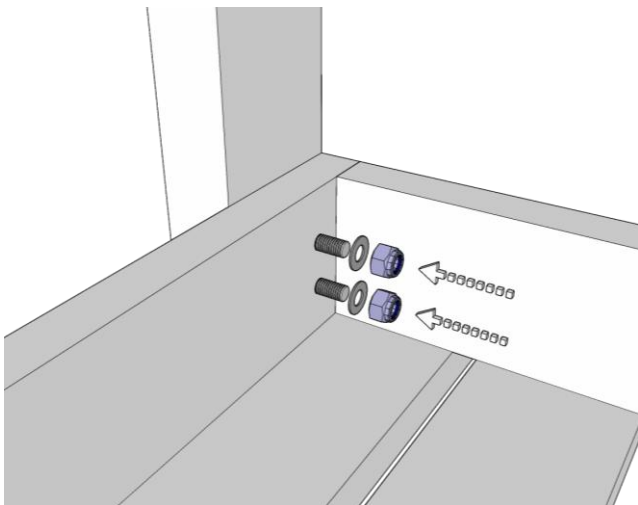

Place an M8 washer and nut onto each bolt and fully tighten.

## Step 12

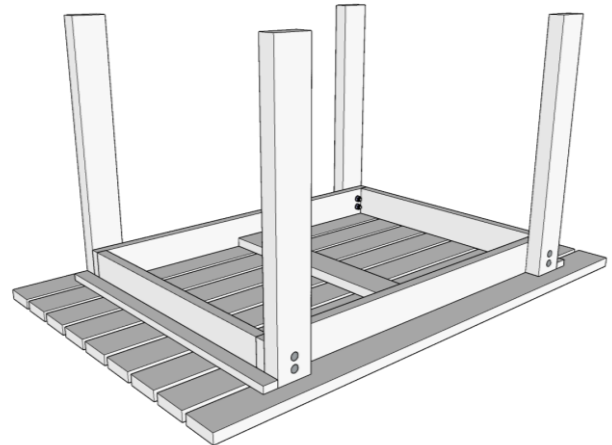

Repeat adding legs in the same fashion until all 4 are attached securely. Your Barrowden set is now complete.

We hope that you found your product quick and easy to assemble but if not and you require any further assistance or have any questions you can contact us by telephone on: **01778 440803**

Email: [info@rutlandcountygardenfurniture.co.uk](mailto:info@rutlandcountygardenfurniture.co.uk) [www.rutlandcountygardenfurniture.co.uk](http://www.rutlandcountygardenfurniture.co.uk)

Rutland County Garden Furniture Ltd, Ashbourne House, 2 Dovecote Meadows,  
Aslackby, Sleaford, Lincs, NG34 0HZ.  
Company No: 7670072 VAT No: 151744027